

Identification plate

**RINGFEDER**  
**耦合器 型号 RF50 CN 版本 B**  
 用于连接 Ø50 牵引环 DIN 74053 或 ISO1102 或 GB/T 4781  
 符合 UNECE R55 生产批号 XXXXX 年/周 YY/WW  
 符合 JT/T 1178.2 & GB/T32860 & ISO 12357 标准  
 规格 C50-7 D 190kN Dc 130 kN  
 S 1000 kg V 75 kN  
 10090757 瑞典制造

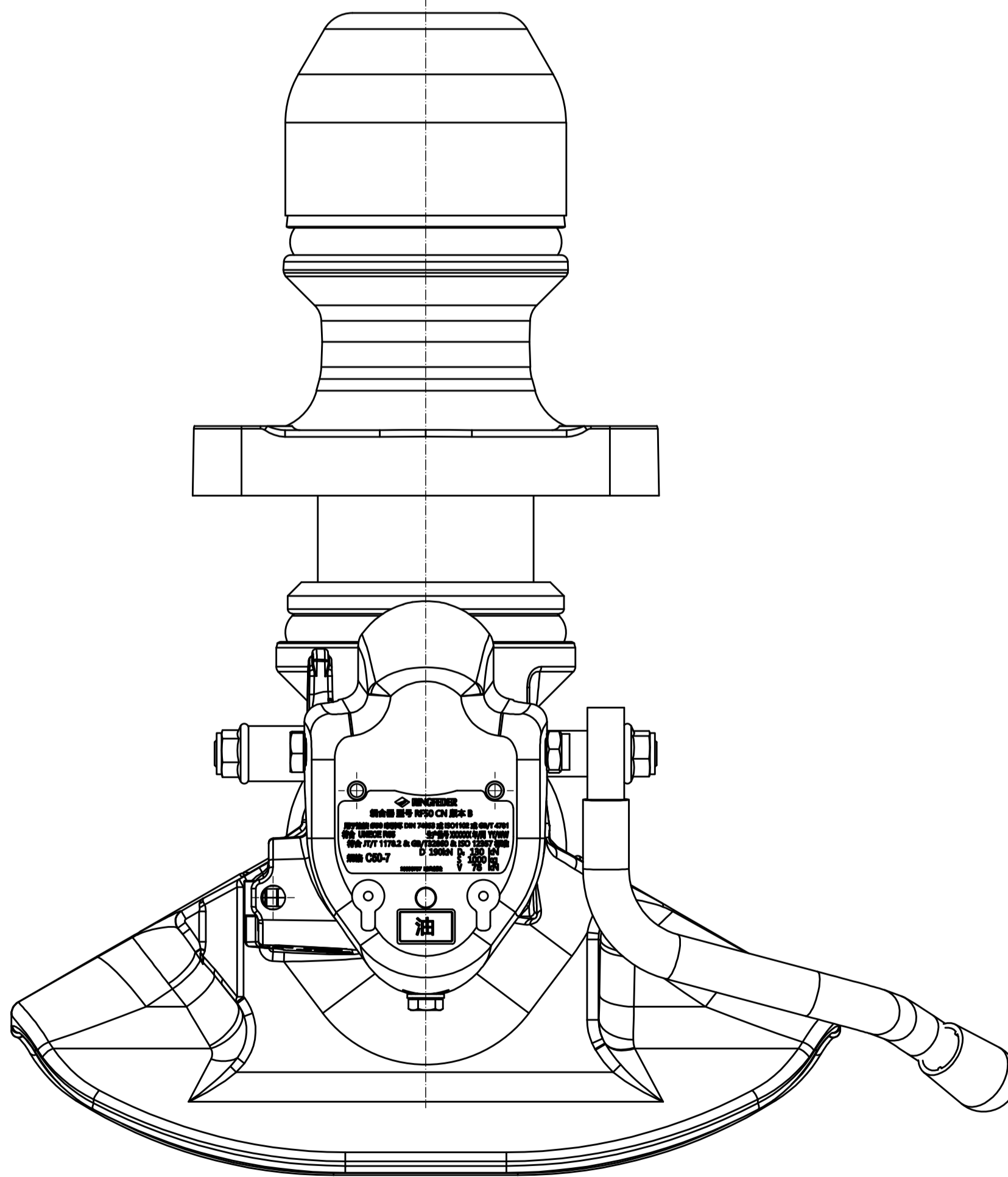
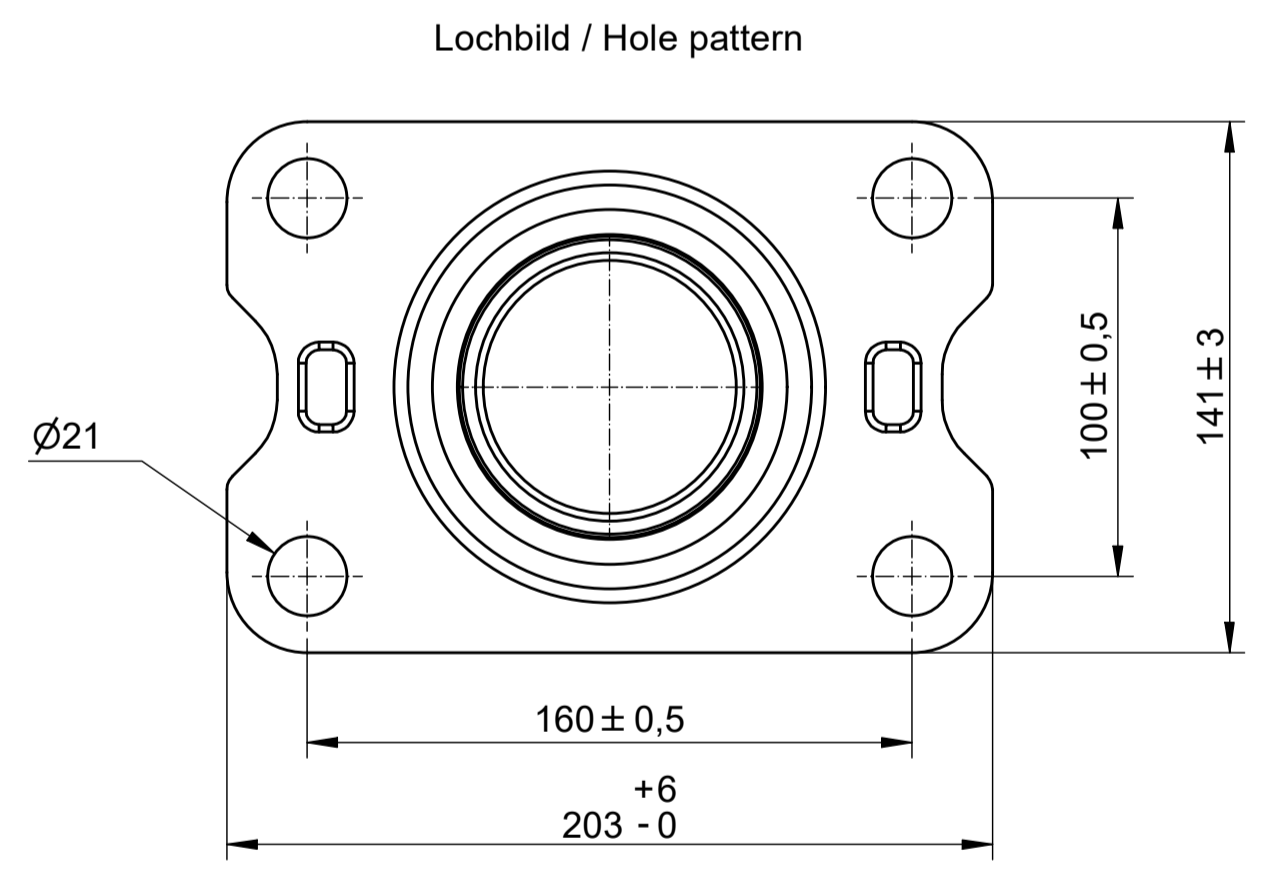

Winkelausschläge der Zugöse:  
 Angle of of drawbar eye:

Horizontal ± 90° min  
 Vertikal ± 20°  
 Axial 360° bei einem Mindestdrehmoment von 100 Nm  
 with a minimum torque of 100 Nm

Fastening torques according to mounting instruction  
 Anzugsmomente gemäß Montageanleitung

<b>RINGFEDER</b>		Modified Date	2021-03-29	Modified by	JL	Modification No.	13001	Issue	b
		3D Model No.	15990829	Engineer	HBH				
<b>VBG GROUP</b>		Sheet Size	A1	Scale	1:2	Production	2019-12-16	Drawn by	HBH
		Description	RF50 CN B	Stage	P	Drawing No.	15990829(F) Info		